

Chain Slings and Fittings

1200 - G80 Master Link with Flat (Welded)

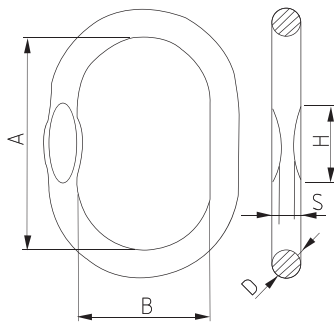

Description:

- Designed for use with steel wire rope or grade 80 alloy steel chain
- For overhead lifting application
- Size, CE, WLL, Traceability code & GRIPTON or GPT embossed

Standard:	EN 1677
Material:	Alloy steel
Factor of safety:	4 to 1
Construction:	Quenched & tempered
Proof load:	2 times of working load limit
Finish:	Powder coated

Master Link with Flat (Welded)

Part No.	Item No.	WLL (T)	A (mm)	B (mm)	D (mm)	S (mm)	H (mm)	Weight (Kg)
1200.0113	13B5	2.6	95	51	13	7	50	0.3
1200.0013	13B6	2.4	115	60	13	7	50	0.35
1200.0016	16B6	3.8	120	70	16	9	70	0.6
1200.0116	16B7	2.8	190	100	16	9	70	86
1200.0020	20B6	6.4	150	80	20	11	50	1.1
1200.0120	20B7	5.8	170	90	20	11	70	1.25
1200.0022	22B6	7.6	170	90	22	12	70	1.53
1200.0122	22B7	6.4	210	110	22	12	70	1.83
1200.0025	25B6	10	190	100	25	13	80	2.21
1200.0028	28B6	12.7	210	110	28	15	80	3.06
1200.0128	28B7	10.5	270	140	28	15	70	3.81
1200.0032	32B6	15.2	270	140	32	17	70	5.05
1200.0038	38B6	25.1	270	140	38	20	55	7.3
1200.0138	38B7	17	420	220	38	20	55	10.78
1200.0045	45B6	34	320	170	45	24	60	12.2
1200.0145	45B7	24.5	470	250	45	24	60	17.06
1200.0050	50B6	40	380	200	50	-	-	17.65
1200.0060	60B6	58	430	220	60	-	-	28.85
1200.0070	70B6	84	500	250	70	-	-	45.48