

General Lifting Gear

5200 - Wire rope pulling hoist

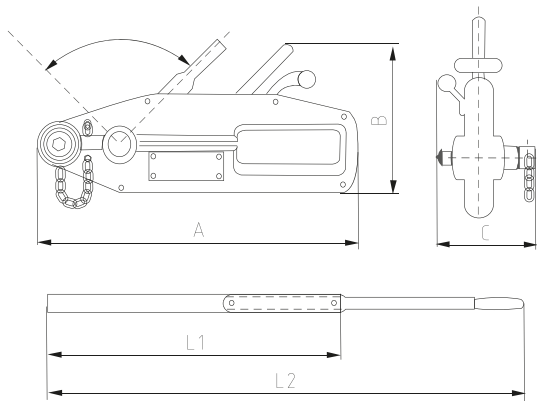

Description:

- Manual pulling machine with lever
- Shear pins provide overload protection
- Used for pulling and lifting
- Rope Dia & H.O.L shown on label and carton

Standard: EN 13157
 Material: Aluminium
 Construction: Quenched & tempered
 Proof load: Individually proof tested to 1.5 time of working load limit
 Finish: Powder coated

Wire rope pulling hoist

Part No.	Rated capacity (T)	Standard rope length (M)	Rope diameter	Effort required at capacity	Wire rope safety factor load capacity	Safety factor & static load capacity	Max. travelling load	A (mm)	B (mm)	C (mm)	L1 (mm)	L2 (mm)	Net weight (Kg)
5200.0080	0.80	20.00	8.30	341.00	5.00	5.00	≥ 52	426.00	238.00	64.00	80.00	80.00	14.60
5200.0160	1.60	20.00	11.00	438.00	5.00	5.00	≥ 55	545.00	284.00	97.00	80.00	120.00	26.40
5200.0320	3.2	20.00	16.00	438.00	5.00	5.00	≥ 28	660.00	325.00	116.00	80.00	120.00	49.30
5200.0540	5.40	20.00	20	745	6	6	≥ 30	930	480.00	152.00	80.00	120.00	98.00